



NAC-2509

15 Watt 8 Ohm Horn Speaker

—

Voice Beyond Limits, Outdoors

Horn Speaker

Waterproof

Fixed Impedance

MAIN FEATURES

- Horn speaker adopts all-weather design, with wide frequency band, clear and bright sound. Widely used in hotels, shopping malls, supermarkets, schools, leisure and entertainment and other public places.
- Horn speaker can be directly connected to the power amplifier or digital audio terminal speaker output.

CIRCUIT DIAGRAM

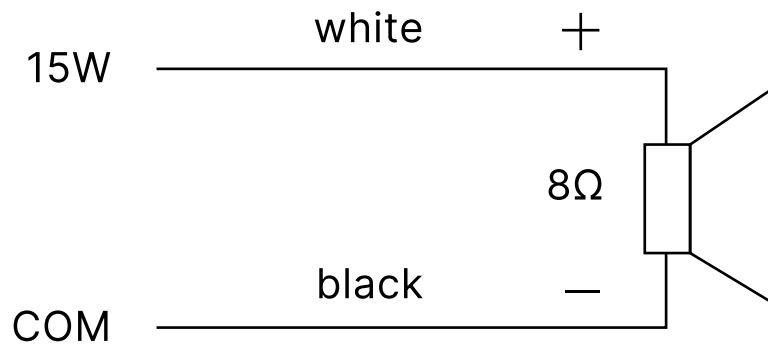

Wiring:

Use 15W rated power: power amplifier speaker output positive pole is connected with white line, power amplifier speaker output negative pole is connected with black line.

SPECIFICATION

ELECTIRC PARAMETERS

Speaker unit	Round Horn Speaker
Max power rate	30W
Rated Power(PHC)	15W
Frequency(1kHz,1meter)	106dB±3dB
Valid Frequency range(-10dB)	380-8kHz
Rated Resistance	8Ω
Cable	2-cable
Color of input port	black,white

WORK INFORMATION

Working temperature	-25°C~+55°C
Working humidity	-40°C~+70°C
Relative humidity	<95%

RAW METERIAL

Host	Aluminum white spray panited
Bracket	Steel grey painted

PRODUCT INFORMATION

Product Size	220×250×170mm
Weight	1.2Kg
Installation method	Wall-mounted

APPLICATIONS

The analog horn speaker NAC-2509 can be connected with constant voltage amplifier for receiving broadcast or announcement from server software or IP paging mic .

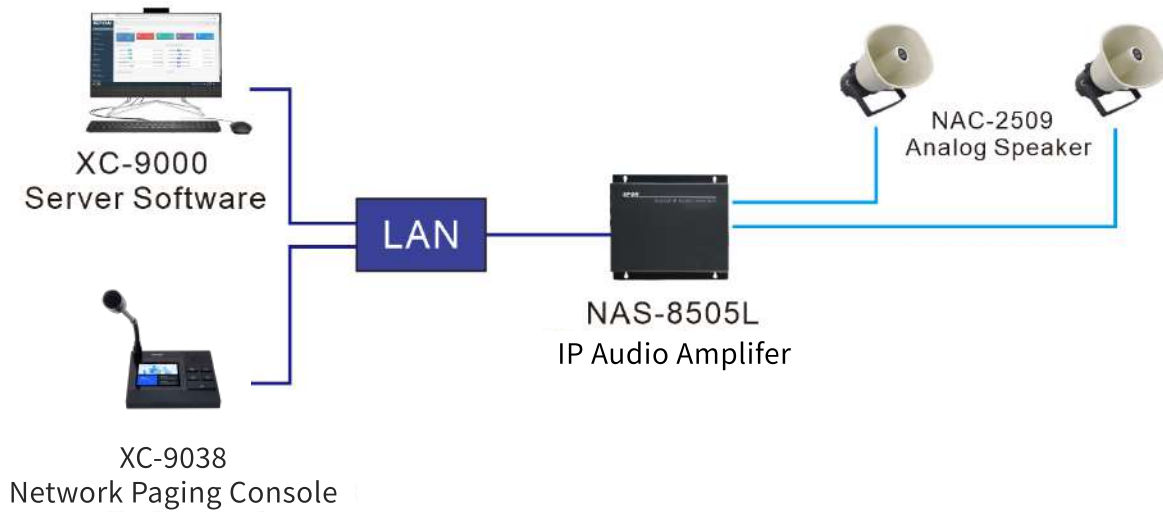

DIMENSION&INSTALLATION

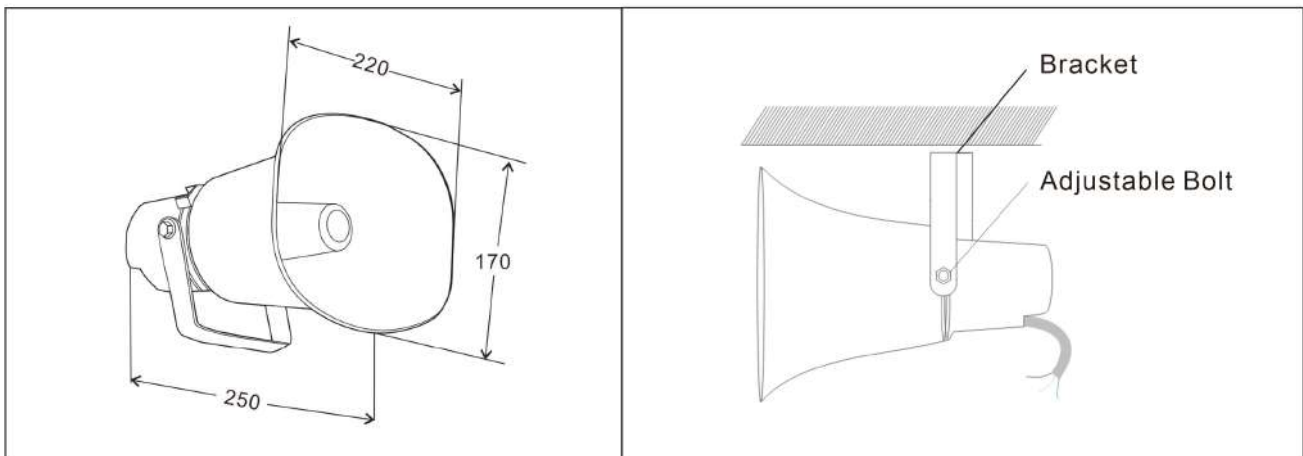

1. The fixing bracket has 3 fixing holes with a diameter of 10mm, which can be fixed with 8~10mm expansion bolts.
2. Adjust the horn projection Angle and tighten the bolts.

CASE

