



## XC-9137AVE

### Network Outdoor Video Intercom

SPON IP POE Outdoor Video Intercom Station XC-9137AVE is designed for outdoor environment use, with embedded installation. This station is typically used as a communication, or emergency point and connects directly to the IP network making it easy to deploy anywhere and at any distance.



## MAIN FEATURES

### 1. Design and Flexible Installation

- Durable, high-grade aluminum alloy panel with an IPX5 protection grade.
- Multiple installation methods including embedded or surface-mounted options.

### 2. Network Integration and Power Supply

- Standard RJ45 interface for Ethernet access, supporting cross-segment and cross-router connectivity.
- POE power supply support for streamlined installation and operation.



### 3. Communication and Connectivity:

- Built-in HD wide-angle camera using H.264 coding for video intercom.
- One-button emergency call for full-duplex audio intercom.
- Compatible with standard SIP protocol for independent registration with VoIP systems (like Asterisk, Yealink, etc.).
- Built-in speaker and microphone for hands-free calls and receiving broadcasts.
- Supports initiating and receiving offline intercom without centralized server software.
- Relay Output and Input interfaces for external device linkage and emergency system integration (buttons, detectors, etc).

# SPECIFICATION

## POWER PARAMETERS

Power Supply: DC 12V/1.5A or  
POE(IEEE802.3af)

Power Consumption: ≤4W

## AUDIO PARAMETERS

Audio Codec: MP2, MP3, PCM, ADPCM

Audio Sampling & Bit Rate: 8kHz~44.1kHz, 16bit,  
8kbps~320kbps

Built-in Speaker: 3W ,4Ω

S/N(Broadcast-Speaker): ≥81dB

THD (Total Harmonic Distortion): <1%

Frequency Response: 20Hz~18KHz

Video Transmission Bit Rate: 512Kbps-4Mbps

Video Coding: VGA/720/1080

Camera Type: CMOS

## NETWORK PARAMETERS

Network I/F: 10BASE-T/100BASE-TX RJ45

Network Protocol: TCP/IP、UDP、ARP、ICMP、  
IGMP、SIP、HTTP

Configuration Method: Web Interface or DevConfig  
Tool

## MECHANICAL&ENVIRONMENT PROPERTIES

Mounting Method: Embedded-mounted

Installation Environment: Outdoor Locations

Operating Temperature: -20°C~+60°C

Operating Humidity: ≤90% RH non-condensing

Front Panel Material: Aluminum Alloy

Color: Silver

Product Dimensions: 100×41×162mm

Protection Level: IPX5

Product Warranty: 2 Years

## ACCESSORIES

1×Waterproof Connector

4×Plastic expansion sleeve(7\*28)

2×Terminal(3.81-2P)

1×Terminal(3.81-3P)

1×Hex Socket Wrench(2.5mm)

1×Power Adaptor(DC12V/1.5A)

4×Half Round Head Phillips Screw(M3\*12)

# INTERFACE DESCRIPTION

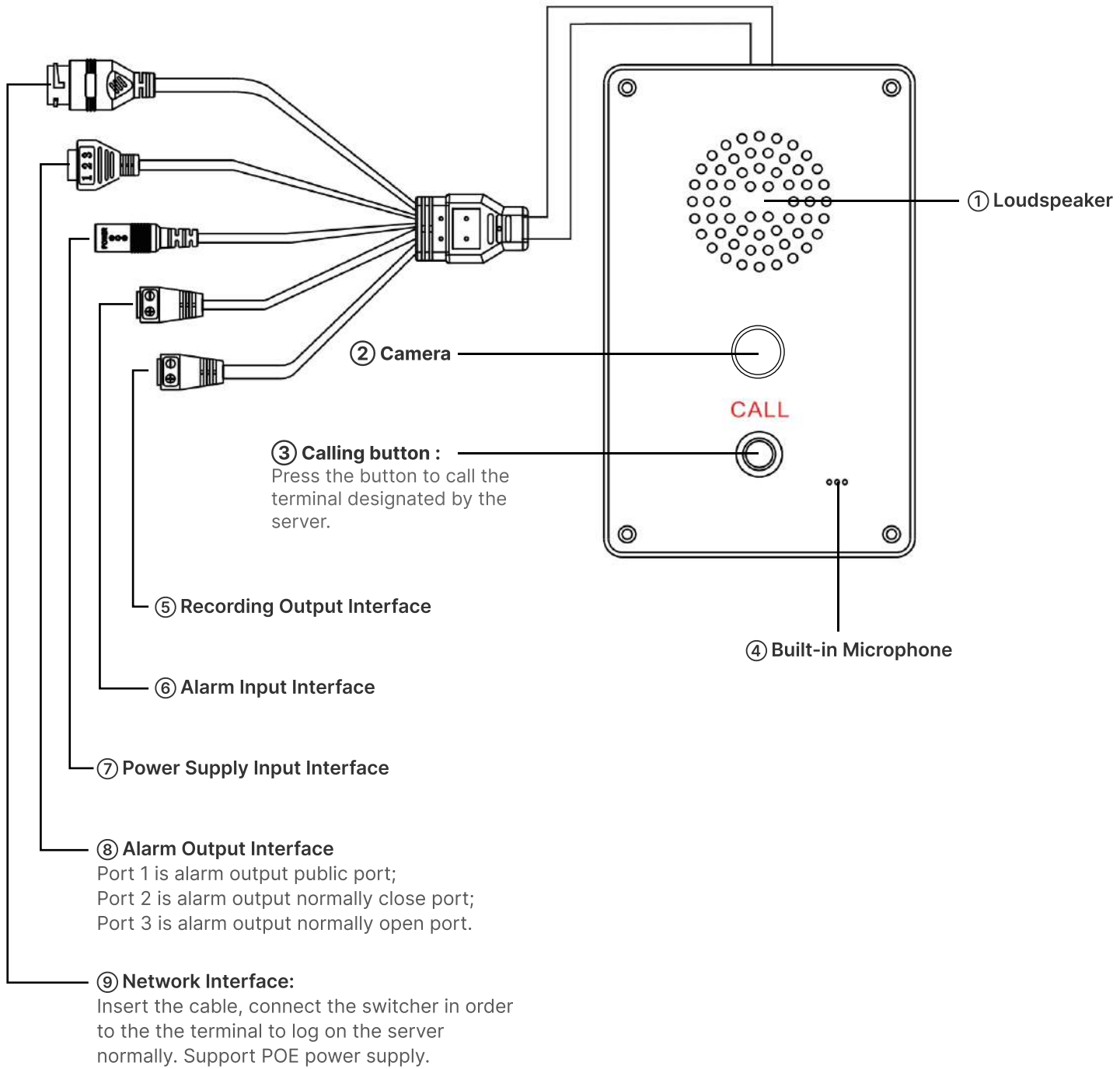

# PORTS DESCRIPTION

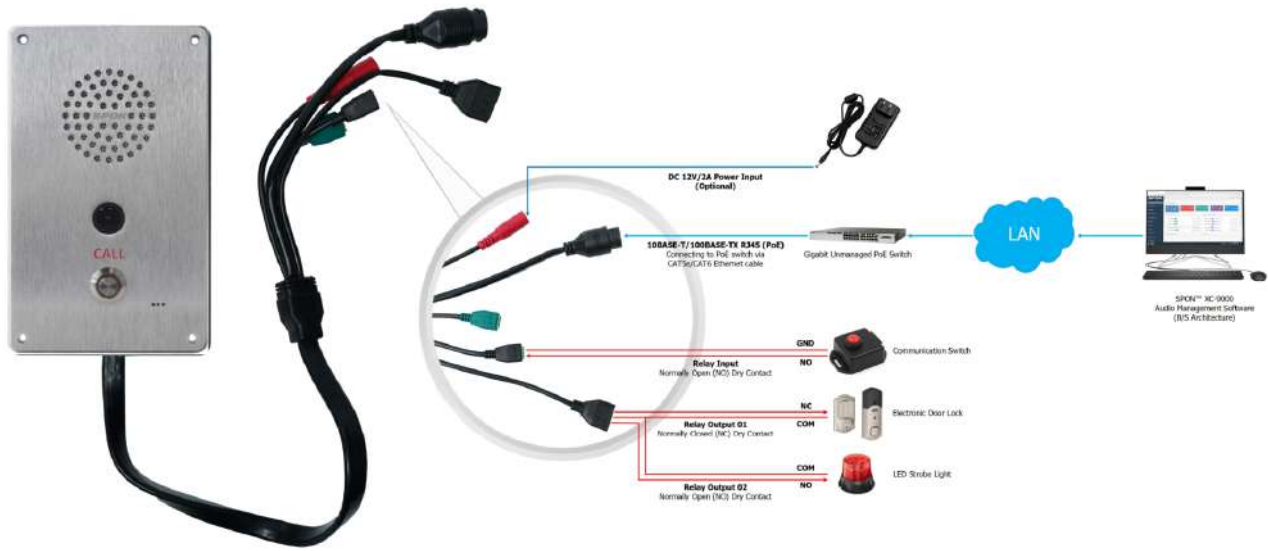

# APPLICATIONS

## Application 1

IP POE Outdoor Video Intercom Station XC-9137AVE can make two-way intercom with IP paging mic and mobile app;In additional,it supports sip protocol, can be registered to mainstream IPPBX to communicate with Sip phone or Sip softphone.

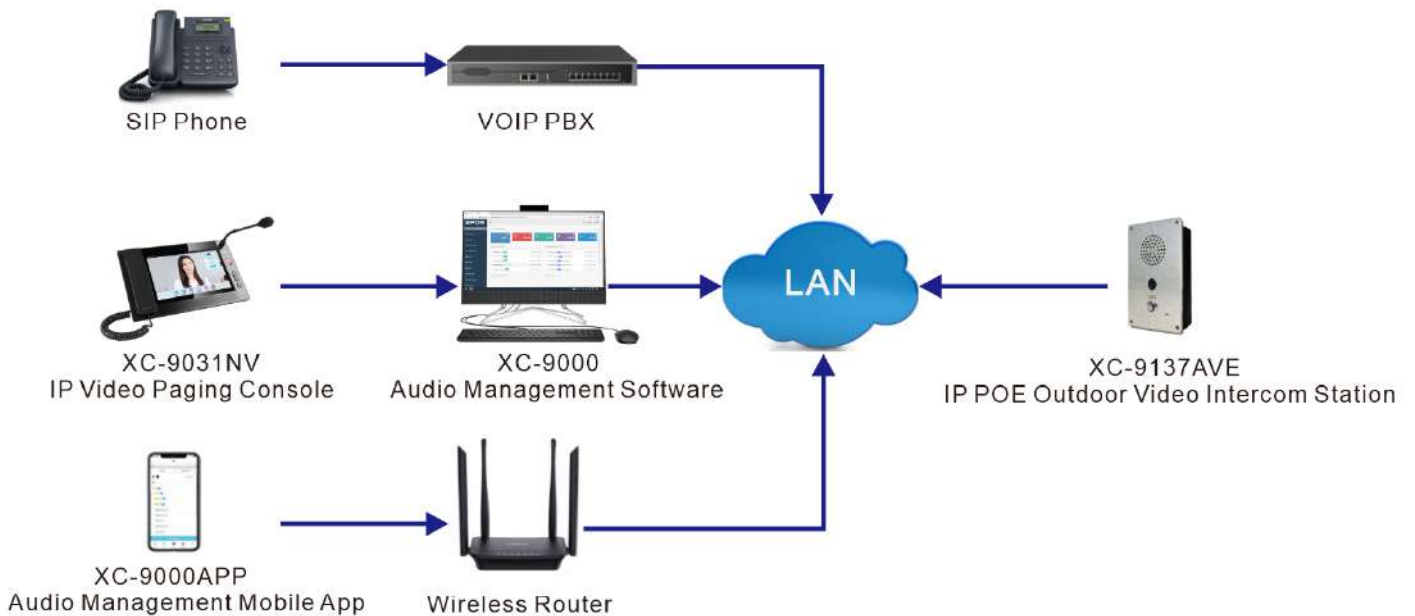

# APPLICATIONS

## Application 2

IP POE Outdoor Video Intercom Station XC-9137AVE with an alarm output interface, which can be connected to an alarm light or door lock. During the intercom with the IP paging microphone, the IP paging microphone can be used to remotely trigger the alarm light alarm or remote unlock.

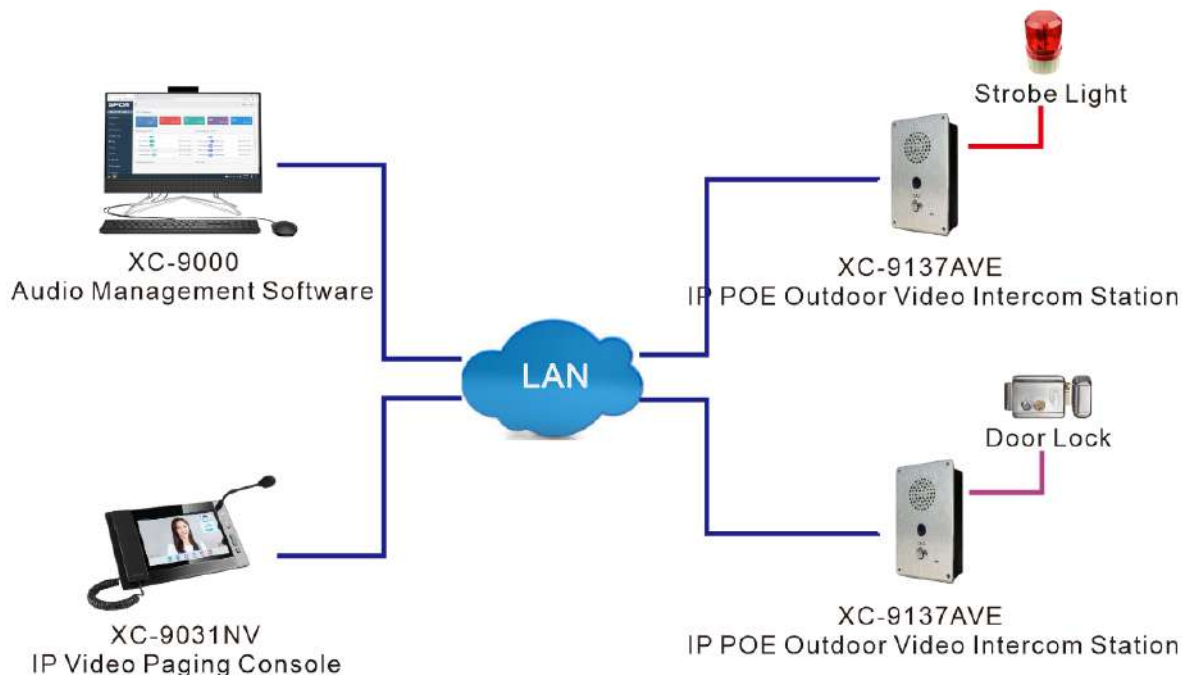

## Application 3

IP POE Outdoor Video Intercom Station XC-9137AVE supports offline intercom function, the offline call target can be set on its webpage .

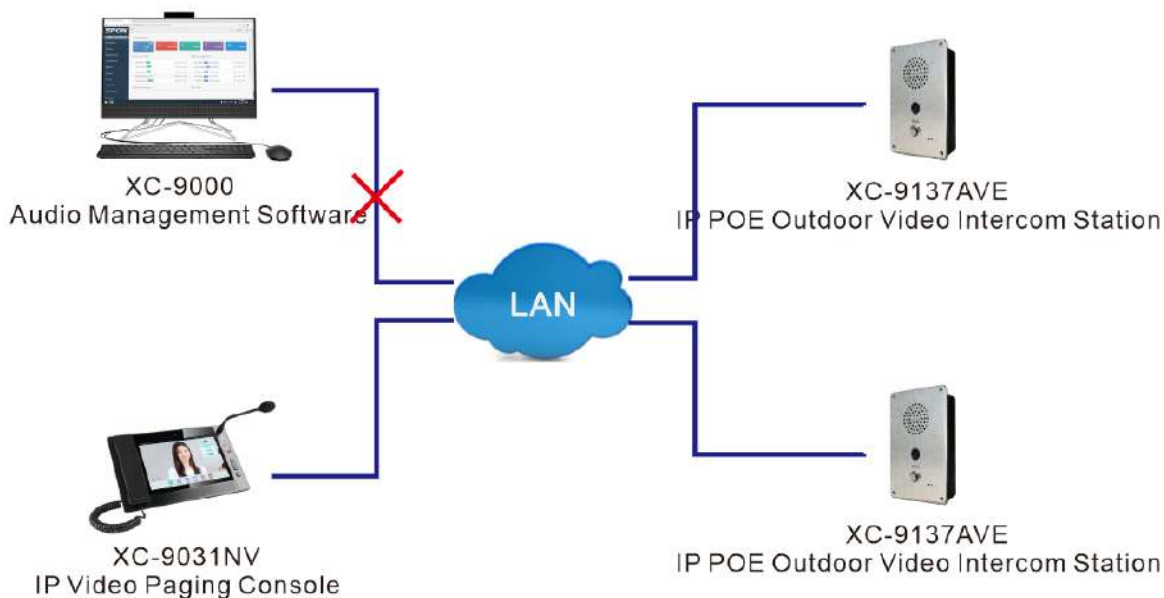

# INSTALLATION

## Installation instructions

First use 4 plastic expansion sleeves and half round head cross screws to install the bottom housing in place, then use 4 M3\*12 inner hexagon screws to secure the panel to the bottom housing (pay attention to perforating the waterproof tail line through the bottom).

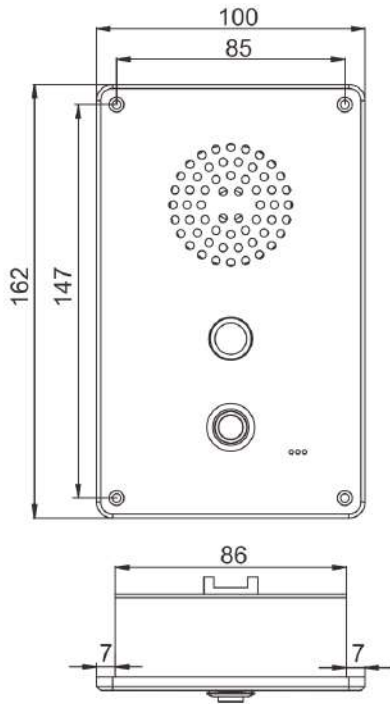

Installation diagram

